

P. WELIN.

TRACKER BOARD FOR AUTOMATIC MUSICAL INSTRUMENTS.

APPLICATION FILED SEPT. 9, 1904. RENEWED MAY 22, 1909.

945,996.

Patented Jan. 11, 1910.

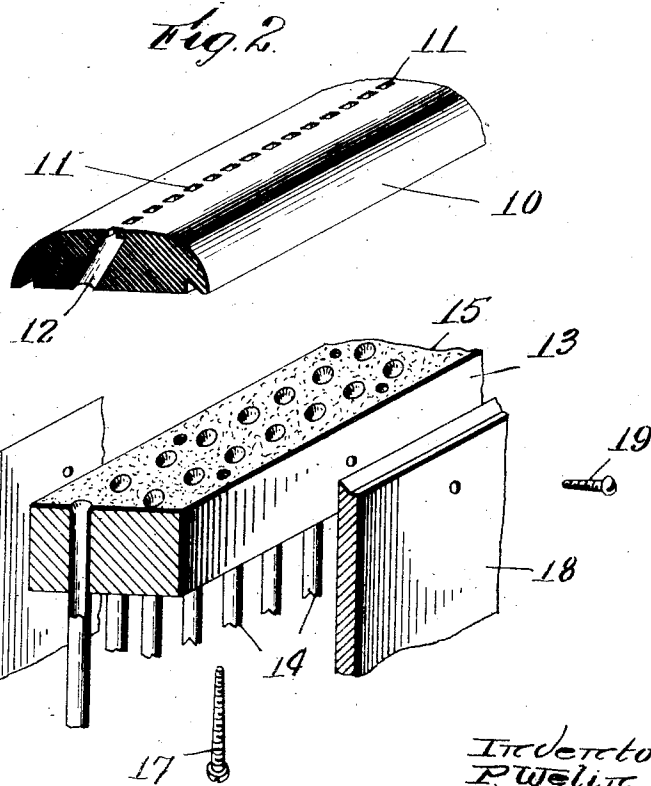
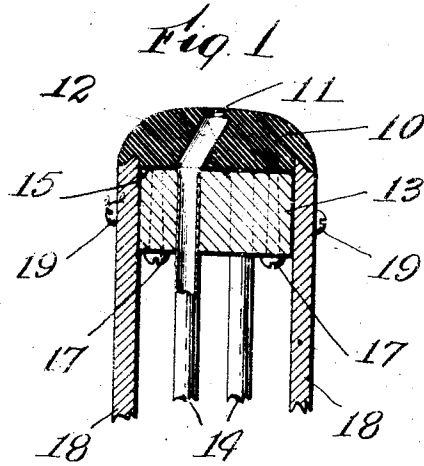

Witnesses:  
C. F. Nilsson.  
A. M. Goodland

Inventor:  
P. Welin.  
By his Attorneys  
Southgate & Southgate

# UNITED STATES PATENT OFFICE.

PETER WELIN, OF WORCESTER, MASSACHUSETTS, ASSIGNOR, BY MESNE ASSIGNMENTS,  
TO KRELL AUTO-GRAND PIANO CO. OF AMERICA, OF CONNERSVILLE, INDIANA, A  
CORPORATION OF INDIANA.

## TRACKER-BOARD FOR AUTOMATIC MUSICAL INSTRUMENTS.

945,996.

Specification of Letters Patent. Patented Jan. 11, 1910.

Application filed September 6, 1904, Serial No. 223,355. Renewed May 22, 1909. Serial No. 497,716.

*To all whom it may concern:*

Be it known that I, PETER WELIN, a citizen of the United States, residing at Worcester, in the county of Worcester and State of Massachusetts, have invented a new and useful Tracker-Board for Automatic Musical Instruments, of which the following is a specification.

This invention relates to a tracker-board construction to be used in an automatic musical instrument to cooperate with a perforated music sheet.

The especial object of this invention is to provide a tracker-board construction which will not warp or crack, and which has accurately spaced perforations.

To these ends, this invention consists of the tracker-board construction and of the combinations of parts therein as hereinafter described and more particularly pointed out in the claims at the end of this specification.

In the accompanying drawing, Figure 1 is a fragmentary sectional view of sufficient parts of a tracker-board construction to illustrate the application of this invention thereto, and Fig. 2 is a fragmentary perspective view showing the parts of the construction detached.

The tracker-boards which are now employed for automatic musical instruments are ordinarily composed of a number of layers of wood which are glued or stuck together. In one ordinary form of construction, a tracker-board comprises a skeleton center-piece having the channels sawed therein from opposite sides; the side pieces which close the channels, and a top plate which contains perforations to cooperate with a music sheet, these parts being glued together to form the completed structure.

In practice, the use of a composite wooden tracker-board is objectionable on account of the liability of the wood to check and warp, and especially for the reason that under certain climatic conditions the glued together joints are liable to break open. To overcome this objection, it has been proposed to employ metal faced tracker-boards, and to accomplish this purpose it has heretofore been the custom to drill or cut out the metallic face-plate of the tracker-board by hand, and it has also been usual to connect the metal tubes to the metallic tracker-board plate by

brazing or soldering the tubes thereto. Metallic tracker-boards, as thus constructed, are objectionable on account of the lack of uniformity with which the holes are drilled therein, and also for the reason that the brazed or soldered joints with the small pipes are readily broken or caused to leak. To overcome these objections, I have provided a tracker-board construction having a metallic top piece which is cast out of a single piece of metal having tracker-board perforations formed during the casting operation.

By casting the tracker-board perforations, each tracker-board is made to conform accurately to a pattern and equal spacing of the perforations is attained. While in order to connect the pipes to the top-plate of the tracker-board, I employ a joint strip in which the expanded ends of the pipes are secured and which is secured directly to the bottom of the metal top-strip of the board construction.

Referring to the accompanying drawing and in detail, the tracker-board construction herein illustrated comprises the metal top-plate 10 having rectangular tracker-board perforations 11 with oppositely inclined passages 12 leading thereto. These perforations are formed in the casting of the metal strip 10 and a uniform spacing of the perforations is thus secured. Fastened to the bottom of the metal top-piece 10 by means of screws 17 is a wooden joint strip 13 in which the expanded ends of the pipes 14 are secured. The upper face of the joint strip 13 is covered with sheep-skin or felt 15 for insuring a tight joint. The under side of the metal top-plate 10 is provided near its edges with dove-tailed sockets for receiving the upper edges of the side panels 18 which are fastened in place by screws 19. In a tracker-board construction thus made up, the pipes are connected to the metal top-plate by a common joint which is not liable to permit individual leakage or the breaking out of any particular pipe, while the casting of the tracker-board perforations in the metal top-plate insures the accurate spacing of the tracker-board perforations.

I am aware that changes may be made in my tracker-board construction by those who are skilled in the art without departing from

the scope of this invention as expressed in the claims. I do not wish to be limited, therefore, to the particular construction I have herein shown and described, but

5 What I do claim and desire to secure by Letters Patent of the United States is:—

1. As an article of manufacture, a tracker-board comprising a single piece of cast metal having recesses or channels staggered or off-  
10 set with respect to each other, smaller top channels for cooperating with the perforations of the music sheet located in line, each of said staggered channels being connected with one of said top channels, all of said  
15 channels being accurately spaced by the casting of the metal, a joint strip connected with the bottom of the metal top piece, pipes secured in the joint strip and communicating with the staggered channels, and side pieces  
20 fitting the sides of the joint strip and the

bottom of the metal top piece and inclosing the pipes.

2. In a tracker-board construction, the combination of a metal top-piece having tracker-board perforations, with oppositely 25 inclined channels therefrom cast in the metal top-piece, a wooden joint strip connected to the bottom of the metal top-piece, pipes having their upper ends expanded to secure them in the joint piece, and side pieces sup- 30 porting the metal top-piece and inclosing the pipes.

In testimony whereof I have hereunto set my hand, in the presence of two subscribing witnesses.

PETER WELIN.

Witnesses:

EDWIN B. PFAU,  
HARRY M. STILWELL.