

P. WELIN.  
 VALVE FOR PNEUMATICALLY CONTROLLED MUSICAL INSTRUMENTS.  
 APPLICATION FILED JAN. 7, 1907. RENEWED JUNE 15, 1909.

945,884.

Patented Jan. 11, 1910.

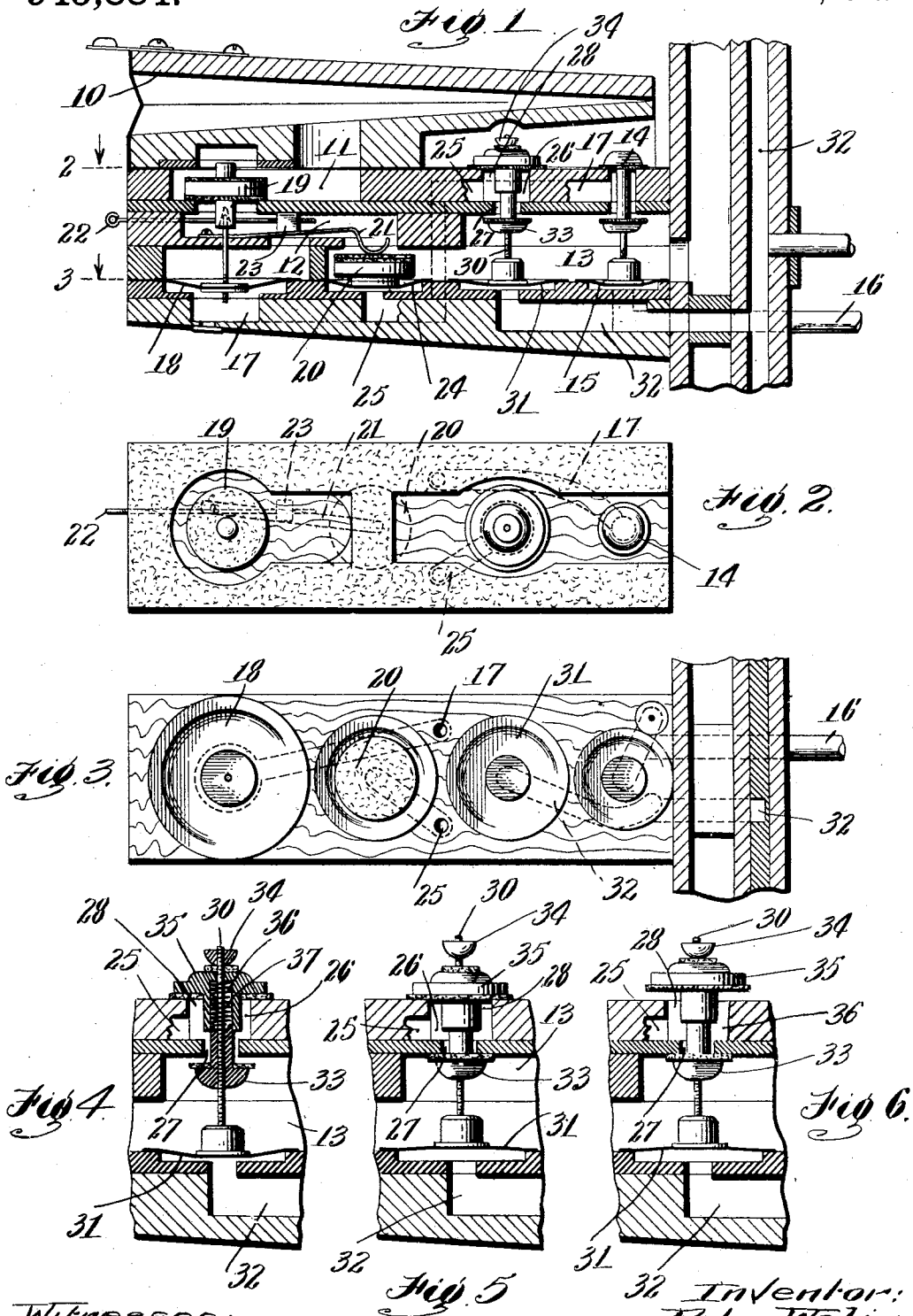

Witnesses:  
 C. F. Mason.  
 M. S. Regan.

Inventor:  
 Peter Welin  
 By Attorneys  
 Southgate & Southgate.

# UNITED STATES PATENT OFFICE.

PETER WELIN, OF NEWCASTLE, INDIANA, ASSIGNOR, BY MESNE ASSIGNMENTS, TO KRELL AUTO-GRAND PIANO CO. OF AMERICA, OF CONNERSVILLE, INDIANA, A CORPORATION OF INDIANA.

VALVE FOR PNEUMATICALLY-CONTROLLED MUSICAL INSTRUMENTS.

945,884.

Specification of Letters Patent. Patented Jan. 11, 1910.

Application filed January 7, 1907, Serial No. 351,089. Renewed June 15, 1909. Serial No. 502,327.

To all whom it may concern:

Be it known that I, PETER WELIN, a citizen of the United States, residing at Newcastle, in the county of Henry and State of Indiana, have invented a new and useful Valve for Pneumatically-Controlled Musical Instruments, of which the following is a specification.

This invention relates to that class of automatic musical instruments in which the striking of the notes is controlled pneumatically and it especially concerns the construction of the valve thereof and the mechanism connected therewith. The valve itself can be used in many places but when combined with other features as this invention contemplates, it is especially adapted to be employed in a valve box connected with a striking pneumatic of an automatic instrument or playing device for ordinary instruments.

This invention in some respects constitutes an improvement over a differential valve originally described and claimed in an application for patent filed by me on the 24th of May, 1904, for an automatic musical instrument, Serial No. 209,449 and specifically claimed in a divisional application of the same filed July 18, 1907, Serial No. 384,361.

The principal objects of the invention are to provide means whereby a valve which normally connects a passage with the suction and is intended to disconnect the passage therefrom upon the taking place of certain operations, will perform this function before it admits air to the passage. The passage preferably is made sufficiently large at the point at which the valve is applied to retain enough suction to hold the part of the valve which controls communication of the passage with the outer air on its seat a short period of time after the other part of the valve is closed. For this purpose the valve is made of a differential character so that the suction passage can be first closed and the air passage opened thereafter.

For an illustration of one embodiment in which the invention can be made and a showing of a particular use of such a valve, reference is to be had to the accompanying drawings in which,

Figure 1 is a longitudinal sectional view of a striking pneumatic and valve box for an automatic piano showing a modulating

valve as constructed in accordance with this invention. Figs. 2 and 3 are horizontal sectional views of the same on the lines 2 and 3 respectively of Fig. 1, and Figs. 4, 5 and 6 are sectional views showing the valve in three different positions.

In the form illustrated in the drawings, the striking pneumatic 10 is connected through passages 11 and 12 with the suction chamber 13 in the valve box. A primary valve 14 is controlled by a pneumatic 15 which is supplied with air through a pipe or passage 16 from the tracker-board in a well known manner. This primary valve connects a passage 17 either with the suction chamber or with the open air and this passage controls a secondary pneumatic 18 which in turn operates a valve 19 for controlling the passage 11, connecting the latter with the suction chamber or with the open air as desired.

A throttle valve 20 is shown for the purpose of producing modulating effects. In the form indicated, this valve is provided with a spring 21 which is made adjustable by means of a screw 22 and a movable block 23 in order to regulate the distance of the valve from its seat when moved upwardly. This throttle valve is operated by a pneumatic 24 which is connected with a passage 25. This passage has an enlarged chamber 26 and is connected with the suction chamber through a port 27 and with the outer air through an opening 28.

It is in position for controlling the connection of the chamber 26 with the suction chamber 13 that the valve which constitutes the principal part of this invention is illustrated, although it will be understood that the same construction of valve could be employed in place of the valve 14 or the valve 19 or in any other position in which valves of this general character are employed. This valve is provided with a stem 30 which is operated by a pneumatic 31 connected in the present case with a modulating channel 32 and operated in any desired way. On the stem 30 is secured a valve member 33. In the form shown, the stem is threaded and this valve member can be adjusted along the stem but when adjusted is substantially fixed to the stem so that it moves vertically with it. On the opposite end of the stem is a nut 34 which is also adjustable and mov-

able with the stem. Between the valve member and nut is movably mounted a second valve member 35 which is free to slide up and down independently of the stem. This member is hollowed out so as to provide a chamber 36 to receive a spring 37 which bears on both of the valve members and normally holds them apart.

Now, referring first to Fig. 4, it will be seen that the valve member 35 is on its seat protecting the passage 25—26 from the admission of atmospheric air. As the pneumatic 31 is down, the spring 37 assists in forcing the valve member 33 downwardly away from its seat so that the passage 25—26 is connected through the port 27 with the suction chamber 13. Now, when air is admitted to the modulating passage 32 the pneumatic will be raised, as shown in Fig. 5. The nut 34 and valve member 33 are necessarily raised with it and as the chamber 26 is considerably larger than the port 27, it retains enough suction or tension to hold the upper valve member 35 down on its seat for a period of time, to give the lower valve 33 time to seat and thoroughly cut off the chamber 26 from the vacuum chamber; the parts will then be in the position shown in Fig. 5. When the parts have adjusted themselves in this position, the tension in the chamber 26 will, as is well understood, be reduced and the spring 37 will have a chance to act to force the valve member 35 into the position shown in Fig. 6 to admit air to the chamber 26 and passage 25. It will be seen, therefore, that the valve is of a differential character so constructed that it will shut off connection between the passage 25 and suction chamber, prior to the admission of air to the passage. This avoids loss of tension such as occurs when valves having rigid valve members are employed and it affords a very simple and convenient construction for accomplishing this result and thus conserving the power of the device. Another advantage is that by the use of the spring valve the two valve members are seated resiliently, thus avoiding any tendency to a noisy operation.

While this invention has been illustrated as in the form of a modulating valve for an automatic musical instrument, it is to be understood that the same is capable of use in place of any and all of the valves employed in such instruments or in piano players and the like and in fact that it can be used with pneumatic motors and accessories therefor in other arts than this one. Moreover, I am aware that modifications may be made in the construction of the device without departing from the spirit of the invention as expressed in the claims, therefore I do not wish to be limited to the particular construction shown, but

What I do claim and desire to secure by Letters-Patent is:—

1. A valve box having a chamber, a suction chamber, a port of smaller cross-section than the chamber and connecting it with the suction chamber, an opening from the chamber to the open air, valves for said opening and port, pneumatic means for positively operating the valve for the port, and resilient means for operating the valve for the opening, said resilient means being supported and controlled by the pneumatic means whereby the valve for the port will be operated before the valve for the opening on the movement of the pneumatic means to close said valve for the port.

2. The combination with a chamber having a port of smaller cross-section than the chamber, and an opening from the chamber to the outer air, of pneumatic means for closing the port and resilient means controlled by the pneumatic means for thereafter gradually opening the opening, said pneumatic means comprising a pneumatic, a valve stem operated thereby, and a valve member on the stem and said resilient means comprising a spring supported by said valve member and a second valve member carried by the spring.

3. A valve comprising a stem, a valve member thereon, a nut adjustable on the stem, a second valve member movable from the first valve member to the nut, and a spring for forcing said valve members apart.

4. A valve comprising a screw-threaded stem, a lower valve member adjustably mounted thereon and adapted to seat upwardly, an upper valve member adapted to seat downwardly and loosely mounted on the stem, a nut arranged on the end of the stem for limiting the motion of the upper valve member, said upper valve member having a chamber therein adapted to receive the upper end of the lower valve member, and a spring in said chamber.

5. In a valve, the combination of a screw-threaded valve stem, two valve members mounted thereon, one of said valve members being adjustably mounted on the stem and having a projection extending toward the other valve member, the other valve member being loosely mounted on the stem and having a chamber therein in which said projection fits, a spring in said chamber, and means on the valve stem for limiting the motion of the movable valve member.

In testimony whereof I have hereunto set my hand, in the presence of two subscribing witnesses.

PETER WELIN.

Witnesses:

ALMA E. YAGER,  
EDWIN B. PFAU.